

# HGL90-12

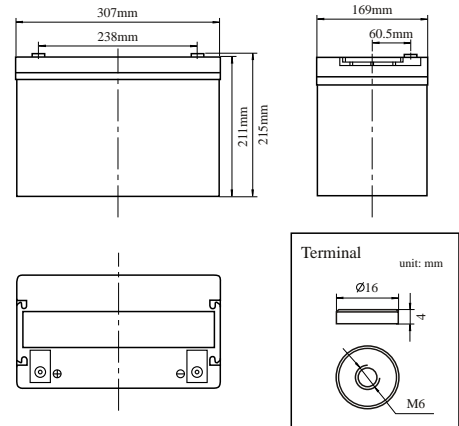

## Specifications

Nominal Voltage		12V
Rated Capacity(20 hour rate)		90AH
Dimension	Total Height (with terminals)	215mm(8.46inches)
	Height	211mm(8.31inches)
	Length	307mm(12.09inches)
	Width	169mm(6.65inches)
Weight		Approx.30.6kg(67.46lbs)

## Discharge characteristics 77°F(25°C)

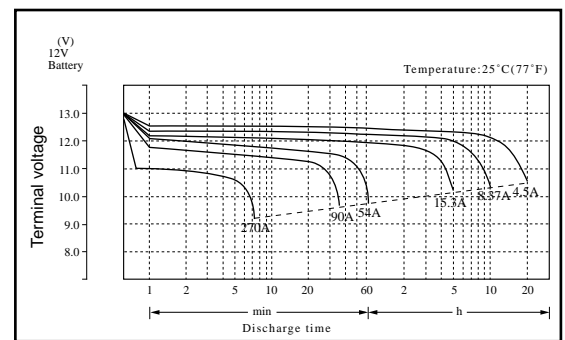

## Characteristics

Capacity 77°F(25°C)	20 hour rate(4.5A)	90AH
	10 hour rate(8.37A)	83.7AH
	5 hour rate(15.3A)	76.5AH
	1 hour rate(54A)	54AH
	15 min rate(157.6A)	39.4AH
Internal Resistance	Full charged Battery 77°F(25°C)	4mΩ
Capacity affected by Temperature (20 hour rate)	104°F(40°C)	102%
	77°F(25°C)	100%
	32°F(0°C)	85%
	5°F(-15°C)	65%
Self-Discharge 77°F(25°C)	Capacity after 3 month storage	91%
	Capacity after 6 month storage	82%
	Capacity after 12 month storage	64%
Max. Discharge Current 77°F(25°C)	1350A(5S)	
Terminal	Standard	F15
	Optional	
Charging (Constant Voltage)	Cycle	Initial Charging Current 18A Or Small 14.5V~14.9V/77°F(25°C)
	Float	13.6V~13.8V/77°F(25°C)

## Duration of discharge vs. Discharge current

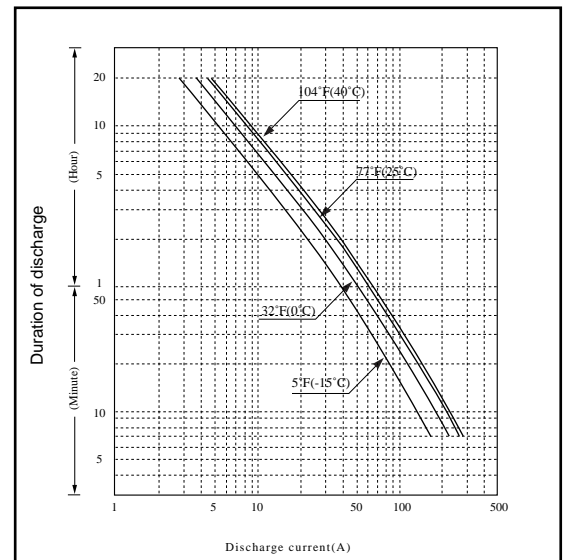

## Constant Power Discharge Watts Per Cell @ 77°F(25°C)

Cut off voltage V/cell	5M	10M	15M	30M	45M	1H	2H	3H	5H	8H	10H	12H	24H
1.60	561	406	325	195	140	109	63.2	44.1	29.6	19.4	16.3	14.1	7.26
1.65	551	402	321	194	139	108	62.8	43.7	29.6	19.4	16.3	14.1	7.26
1.67	544	398	315	192	138	107	62.4	43.4	29.6	19.4	16.3	14.1	7.26
1.70	527	386	304	187	134	106	62.1	43.0	29.6	19.4	16.3	14.1	7.26
1.75	505	369	292	180	131	104	61.5	42.5	29.2	19.1	16.2	14.1	7.26
1.80	483	354	279	173	128	102	60.9	42.0	28.8	18.8	15.9	13.9	7.26

**Note** The above data are average values, and can be obtained within 3 charge/discharge cycles. These are not minimum values.

## FULLRIVER HGL BATTERIES

This information is generally descriptive only and is not intended to make or imply any representation, guarantee or warranty with respect to any cells and batteries. Cell and battery designs/specifications are subject to modification without notice. Contact Fullriver for the latest information.